

BBC INDUSTRIES, INC.
AIR FLASH



AIR FLASH
ASSEMBLY INSTRUCTIONS

Document # 16-427

General Operating Instructions:

1. Adjust height of heater above platen to suit specific conditions.
2. Rotate knob to level heater above platen.
3. Adjust temperature heat setting.
4. Air Flash will heat to operating temperature in approximately 5 minutes.
5. All operating/curing temperatures should be checked with a temperature monitoring device of your choice.
6. Pretest all curing situations, inks and substrates before proceeding.
7. Position magnetic handle for operator convenience.

CAUTION
HEAT PRODUCING UNIT
DO NOT LEAVE HEATER UNATTENDED

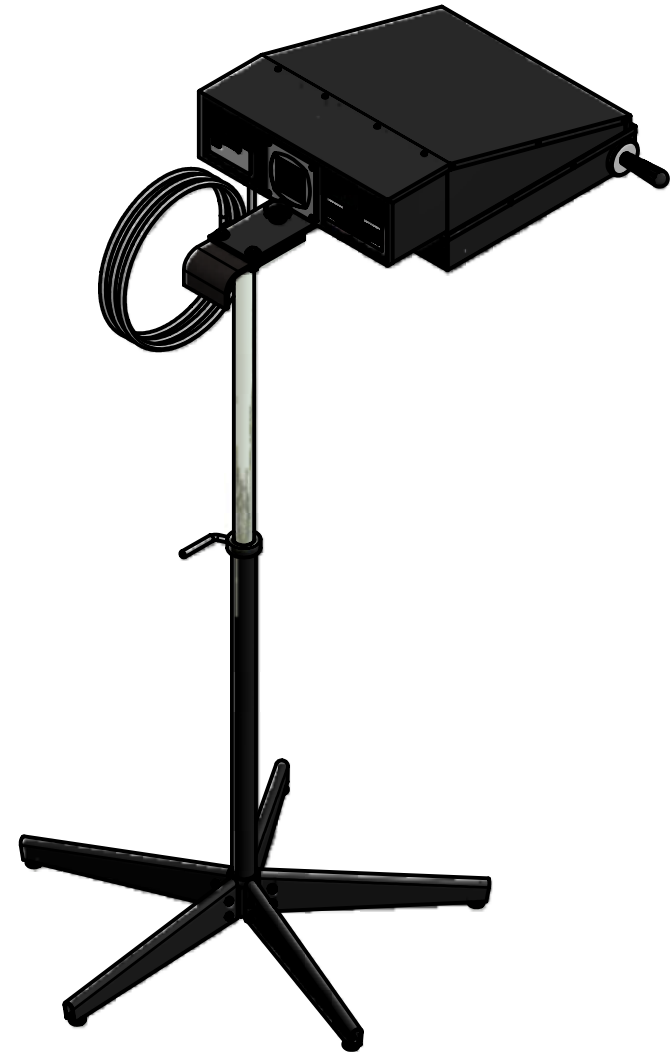

PARTS LIST			
ITEM	QTY	PART NUMBER	DESCRIPTION
1	1	N/A	HEATER HEAD
2	1	97-183	Rotating Shaft for Stands
3	1	BFL-01	BF Leveler-Threaded plate W/Handle Bend
4	1	13-141	COLLAR 1 7/16 ID W/Setscrew
5	1	97-184	BENT BOLT
6	1	97-185	GRIP .31 ID x 2.75L
7	2	25-194	Bolt-5/16-18 x 1-1/2 HHCS ACG Black
8	4	23-007	WASHER 5/16 BO
9	1	93-022	KNOB 5/16-18
10	2	23-008	WASHER-LOCK 5/16" BO
11	2	24-009	NUT-5/16-18 BO HEX
12	1	97-181	Support Tube for BF Stand
13	5	97-182	Std. Duty Stand Legs-16"
14	5	90-580	LEVELING FEET-Bf Stand 5/16-18 Thread
15	10	25-008	HEX BOLT 1/4-20 x 1.25
16	10	23-005	WASHER LOCK 1/4 SPLIT BO
17	10	24-004	HEX NUT 1/4-20 BO

Tools Required: 1/2" and 7/16" open end wrench
IMPORTANT: BE SURE ALL PARTS ARE ENCLOSED.

1. Position Heater Head (1) face on flat level surface.
2. Install feet (14) to legs (13).
3. Install legs (13) to tube (12) with Bolts (15), washer (16) & nut (17).
4. Install tube (2), collar (4), bent bolt (5) into tube (12)
5. Slide tube (2) up & lock collar (4) to mate with leveler (3) & heater head (1) bracket.
6. Install bolts (7), washers (8), washers (10), fiber washer (18) & nuts (11)
 Note: Must position fiber washers (18) between leveler (3) & heaters head (1) bracket
7. Install knob (9) & fiber washer (18) into Leveler (3)
 Note: Must position fiber washers (18) between leveler (3) & heaters head (1) bracket

